

How to Read a Performance Pipe Gas Printline

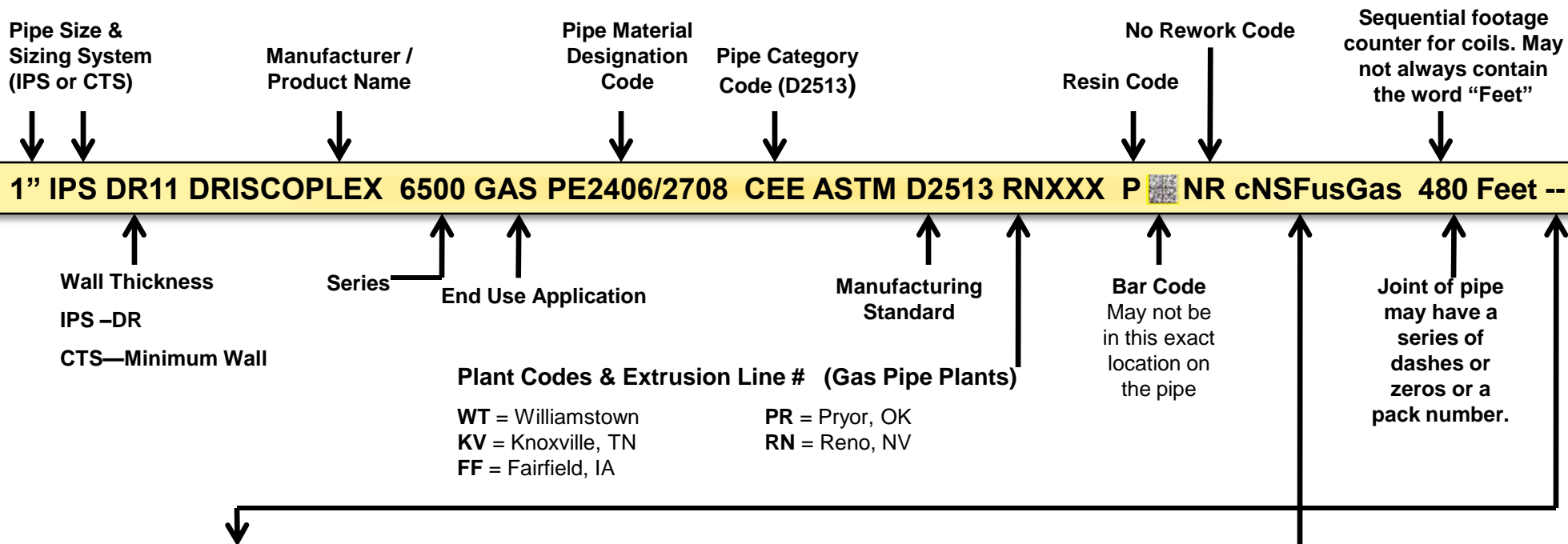

Additional tracking information, not shown, that follows the sequential footage data; The order may vary by plant.

- Shift & Operator Number
- Date of Manufacture
- Coil or Bundle/Pack Number (The word coil or pack will precede the respective number)

Third Party Compliance may vary depending on the listing requested: Fairfield and Pryor plants are not certified through NSF and may appear without NSF in printline.

CSA Product Only - cNSFus Gas B137.4

UPC Product Only - NSF GAS U.P. Code

CSA and UPC Product - cNSFus GAS U.P.Code B137.4